	Datasheet	No.	DS10-E016
		Initial Date	2016-05-18
OE	OEFS341	Written Team	R&D Dept.
			GH Zheng

### I Preview

PN	OEFS341
Description	16G SFP+ LW 1310nm 10KM DDMI 0~70 °C

### II Contents

1. Features
2. Applications
3. Description
4. Absolute maximum Ratings
5. Operating Environment
6. Optical and Electrical Characteristics
7. Timing and Electrical
8. Diagnostics
9. Digital Diagnostic Memory Map
10. Pin Descriptions
11. Recommended Interface Circuit
12. Mechanical Dimensions
13. Model Ordering Information

### III Revision History

No.	Date	Items	Change Recording	Ver.	Rev.	Customer
1	2016-05-18	All	Initial registration	000	000	Standard
2						
3						
4						
5						
6						

 Communication Limited	Datasheet		DS10-E016 Final Rev.:2016.5.18	
	Product	16G SFP+ transceiver OE serials	Ver.	000
	Part No.	OEFS341	Rev.	000
			Page	2 / 8

### 1. Features:

- ◆ Supports up to 14.025Gbps bit rates
- ◆ Hot-pluggable SFP+ footprint
- ◆ 1310nm DFB laser and PIN photodiode, Up to 10km for SMF transmission
- ◆ Compliant with SFP+ MSA and SFF-8472 with duplex LC receptacle
- ◆ Compatible with RoHS
- ◆ Single +3.3V power supply
- ◆ Real Time Digital Diagnostic Monitoring
- ◆ Operating case temperature: 0 to +70°C

### 2. Applications

- ◆ 4.25/8.5/14.025G Fiber channel

### 3. Description

The 16G SFP+ transceivers are high performance, cost effective modules supporting data rate of 14.025Gbps and 10km transmission distance with SMF. The transceiver consists of three sections: a DFB laser transmitter, a PIN photodiode integrated with a trans-impedance preamplifier (TIA) and MCU control unit. All modules satisfy class I laser safety requirements. The transceivers are compatible with SFP Multi-Source Agreement and SFF-8472 digital diagnostics functions.

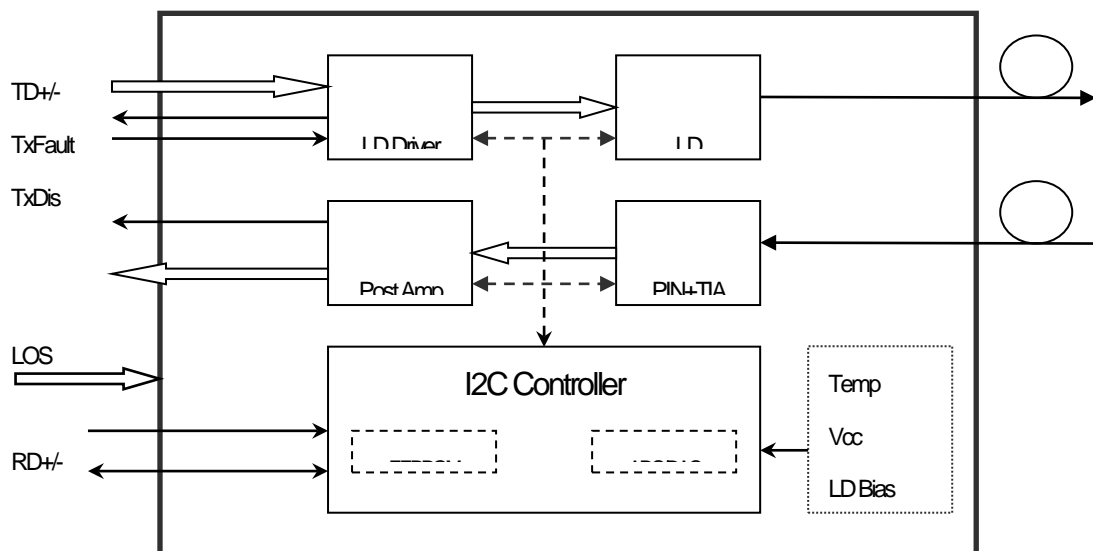

**Transceiver functional diagram**

OCRE COMMUNICATION LIMITED Web: ww.ocrecom.com E-Mail: sales@ocrecom.com Add. Dist.A, Building 6, Bay on the six block, Xixiang, Baoan Dist, Shenzhen, China 518000 Tel: + 86 755 2335 3855 Fax: + 86 755 2335 3855	DESIGN	CHECK	CHECK	APPROVAL

 Communication Limited	Datasheet		DS10-E016 Final Rev.:2016.5.18	
	Product	16G SFP+ transceiver OE serials	Ver.	000
	Part No.	OEFS341	Rev.	000
			Page	3 / 8

#### 4. Absolute Maximum Ratings

Parameter	Symbol	Min	Max	Unit
Supply Voltage	V <sub>cc</sub>	-0.5	4.5	V
Storage Temperature	T <sub>s</sub>	-40	+85	°C
Operating Humidity	-	5	85	%

#### 5. Operating environment

Parameter	Symbol	Min	Typical	Max	Unit
Operating Case Temperature	T <sub>c</sub>	0		+70	°C
Power Supply Voltage	V <sub>cc</sub>	3.135	3.30	3.465	V
Power Supply Current	I <sub>cc</sub>			350	mA
Data Rate			14.025		Gbps

#### 6. Optical and Electrical Characteristics

Parameter	Symbol	Min	Typical	Max	Unit	Notes
<b>Transmitter</b>						
Centre Wavelength	$\lambda_c$	1270	1310	1350	nm	
Spectral Width (-20dB)	$\Delta\lambda$			1	nm	
Side-Mode Suppression Ratio	SMSR	30	-		dB	
Average Output Power	P <sub>out</sub>	-5		-0.5	dBm	1
Extinction Ratio	ER	3.5			dB	
Data Input Swing Differential	V <sub>N</sub>	180		850	mV	2
Input Differential Impedance	Z <sub>N</sub>	90	100	110	$\Omega$	
TX Disable	Disable	2.0		V <sub>cc</sub>	V	
	Enable	0		0.8	V	
TX Fault	Fault	2.0		V <sub>cc</sub>	V	
	Normal	0		0.8	V	
<b>Receiver</b>						
Centre Wavelength	$\lambda_c$	1260		1600	nm	
Receiver Sensitivity				-12	dBm	3
Receiver Overload		0.5			dBm	3
LOS De-Assert	LOS <sub>D</sub>			-13	dBm	
LOS Assert	LOS <sub>A</sub>	-30			dBm	
LOS Hysteresis		0.5			dB	

OCRE COMMUNICATION LIMITED Web: ww.ocrecom.com E-Mail: sales@ocrecom.com Add. Dist.A, Building 6, Bay on the six block, Xixiang, Baoan Dist, Shenzhen, China 518000 Tel: + 86 755 2335 3855 Fax: + 86 755 2335 3855	DESIGN	CHECK	CHECK	APPROVAL

 Communication Limited	Datasheet		DS10-E016 Final Rev.:2016.5.18	
	Product	16G SFP+ transceiver OE serials	Ver.	000
	Part No.	OEFS341	Rev.	000
			Page	4 / 8

Data Output Swing Differential	V <sub>out</sub>	300	900	mV	4
LOS	High	2.0	V <sub>cc</sub>	V	
	Low		0.8	V	

**Notes:**

1. The optical power is launched into SMF.
2. PECL input, internally AC-coupled and terminated.
3. Measured with a PRBS 2<sup>31</sup>-1 test pattern @ 14025Mbps, BER ≤ 1×10<sup>-12</sup>.
4. Internally AC-coupled.

**7. Timing and Electrical**

Parameter	Symbol	Min	Typical	Max	Unit
Tx Disable Negate Time	t <sub>on</sub>			1	ms
Tx Disable Assert Time	t <sub>off</sub>			10	μs
Time To Initialize, including Reset of Tx Fault	t <sub>init</sub>			300	ms
Tx Fault Assert Time	t <sub>fault</sub>			100	μs
Tx Disable To Reset	t <sub>reset</sub>	10			μs
LOS Assert Time	t <sub>loss_on</sub>			100	μs
LOS De-assert Time	t <sub>loss_off</sub>			100	μs
Serial ID Clock Rate	f <sub>serial_clock</sub>		100	400	KHz
MOD_DEF (0:2)-High	V <sub>H</sub>	2		V <sub>cc</sub>	V
MOD_DEF (0:2)-Low	V <sub>L</sub>			0.8	V

**8. Diagnostics**

Parameter	Range	Unit	Accuracy	Calibration
Temperature	0 to +70	°C	±3°C	Internal
Voltage	3.0 to 3.6	V	±3%	Internal
Bias Current	0 to 100	mA	±10%	Internal
TX Power	-6.5 to -0.5	dBm	±3dB	Internal
RX Power	-20 to -1	dBm	±3dB	Internal

OCRE COMMUNICATION LIMITED Web: ww.ocrecom.com E-Mail: sales@ocrecom.com Add. Dist.A, Building 6, Bay on the six block, Xixiang, Baoan Dist, Shenzhen, China 518000 Tel: + 86 755 2335 3855 Fax: + 86 755 2335 3855	DESIGN	CHECK	CHECK	APPROVAL

 Communication Limited	Datasheet		DS10-E016 Final Rev.:2016.5.18	
	Product	16G SFP+ transceiver OE serials	Ver.	000
	Part No.	OEFS341	Rev.	000
			Page	5 / 8

### 9. Digital Diagnostic Memory Map

The transceivers provide serial ID memory contents and diagnostic information about the present operating conditions by the 2-wire serial interface (SCL, SDA). The diagnostic information with internal calibration or external calibration all are implemented, including received power monitoring, transmitted power monitoring, bias current monitoring, supply voltage monitoring and temperature monitoring.

The digital diagnostic memory map specific data field defines as following.

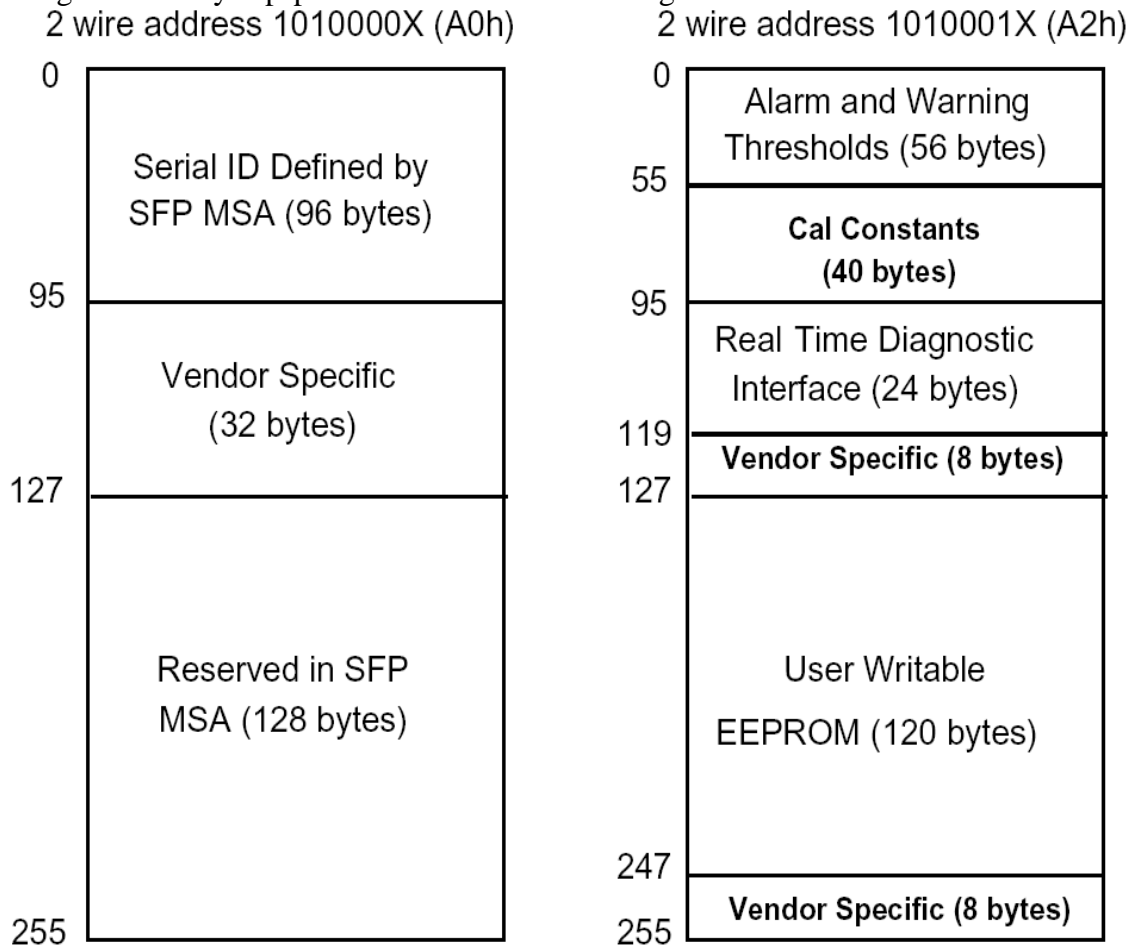

OCRE COMMUNICATION LIMITED Web: ww.ocrecom.com E-Mail: sales@ocrecom.com Add. Dist.A, Building 6, Bay on the six block, Xixiang, Baoan Dist, Shenzhen, China 518000 Tel: + 86 755 2335 3855 Fax: + 86 755 2335 3855	DESIGN	CHECK	CHECK	APPROVAL

 Communication Limited	Datasheet		DS10-E016 Final Rev.:2016.5.18	
	Product	16G SFP+ transceiver OE serials	Ver.	000
	Part No.	OEFS341	Rev.	000
			Page	6 / 8

## 10. Pin Descriptions

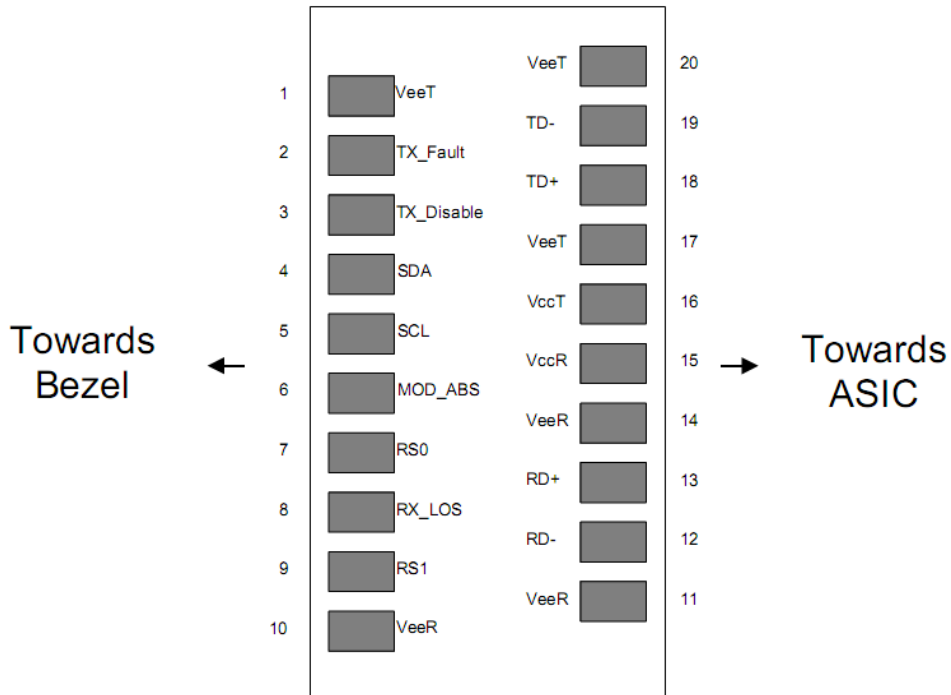

Pin	Signal Name	Description	Plug Seq.	Notes
1	V <sub>EET</sub>	Transmitter Ground	1	
2	TXFAULT	Transmitter Fault Indication	3	Note 1
3	TXDISABLE	Transmitter Disable	3	Note 2
4	SDA	SDA Serial Data Signal	3	
5	SCL	SCL Serial Clock Signal	3	
6	MOD_ABS	Module Absent. Grounded within the module	3	
7	RS0	Not Connected	3	
8	LOS	Loss of Signal	3	Note 3
9	RS1	Not Connected	3	
10	V <sub>EER</sub>	Receiver ground	1	
11	V <sub>EER</sub>	Receiver ground	1	
12	RD-	Inv. Received Data Out	3	Note 4
13	RD+	Received Data Out	3	Note 4
14	V <sub>EER</sub>	Receiver ground	1	
15	V <sub>CCR</sub>	Receiver Power Supply	2	
16	V <sub>CCT</sub>	Transmitter Power Supply	2	
17	V <sub>EET</sub>	Transmitter Ground	1	

OCRE COMMUNICATION LIMITED Web: ww.ocrecom.com E-Mail: sales@ocrecom.com Add. Dist.A, Building 6, Bay on the six block, Xixiang, Baoan Dist, Shenzhen, China 518000 Tel: + 86 755 2335 3855 Fax: + 86 755 2335 3855	DESIGN	CHECK	CHECK	APPROVAL

 CRE Communication Limited	Datasheet		DS10-E016 Final Rev.:2016.5.18	
	Product	16G SFP+ transceiver OE serials	Ver.	000
	Part No.	OEFS341	Rev.	000
			Page	7 / 8

18	TD+	Transmit Data In	3	Note 5
19	TD-	Inv. Transmit Data In	3	Note 5
20	V <sub>EET</sub>	Transmitter Ground	1	

Notes:

Plug Seq.: Pin engagement sequence during hot plugging.

- 1) TX Fault is an open collector output, which should be pulled up with a 4.7k~10kΩ resistor on the host board to a voltage between 2.0V and V<sub>cc</sub>+0.3V. Logic 0 indicates normal operation; Logic 1 indicates a laser fault of some kind. In the low state, the output will be pulled to less than 0.8V.
- 2) Laser output disabled on TDIS >2.0V or open, enabled on TDIS <0.8V.
- 3) LOS is open collector output. Should be pulled up with 4.7k~10kΩ on host board to a voltage between 2.0V and 3.6V. Logic 0 indicates normal operation; logic 1 indicates loss of signal.
- 4) RD-/+ : These are the differential receiver outputs. They are internally AC-coupled 100 differential lines which should be terminated with 100Ω (differential) at the user SERDES.
- 5) TD-/+ : These are the differential transmitter inputs. They are internally AC-coupled, differential lines with 100Ω differential termination inside the module.

### 11. Recommended Interface Circuit

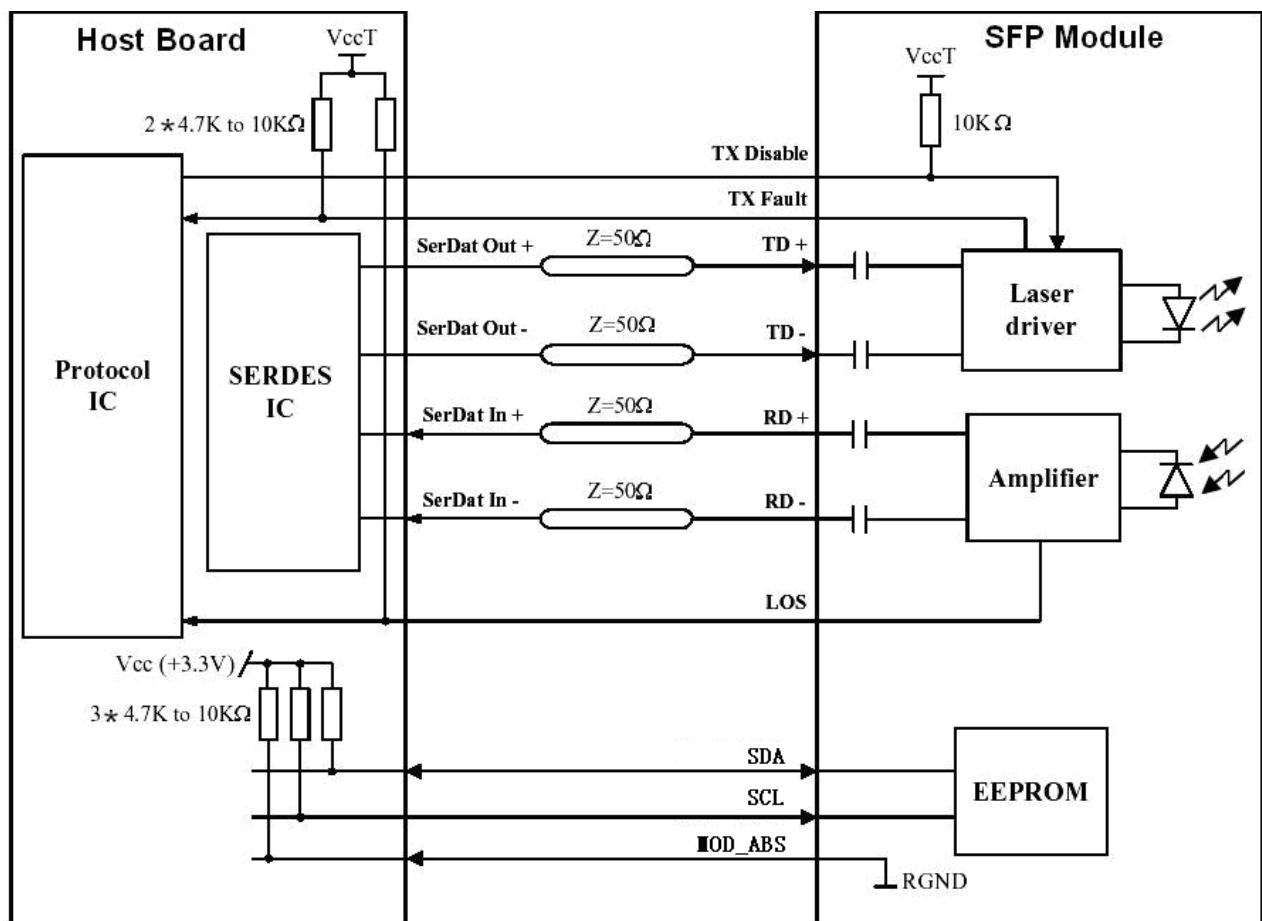

OCRE COMMUNICATION LIMITED Web: ww.ocrecom.com E-Mail: sales@ocrecom.com Add. Dist.A, Building 6, Bay on the six block, Xixiang, Baoan Dist, Shenzhen, China 518000 Tel: + 86 755 2335 3855 Fax: + 86 755 2335 3855	DESIGN	CHECK	CHECK	APPROVAL

 CRE Communication Limited	Datasheet		DS10-E016 Final Rev.:2016.5.18	
	Product	16G SFP+ transceiver OE serials	Ver.	000
	Part No.	OEFS341	Rev.	000
			Page	8 / 8

## 12. Mechanical Dimensions

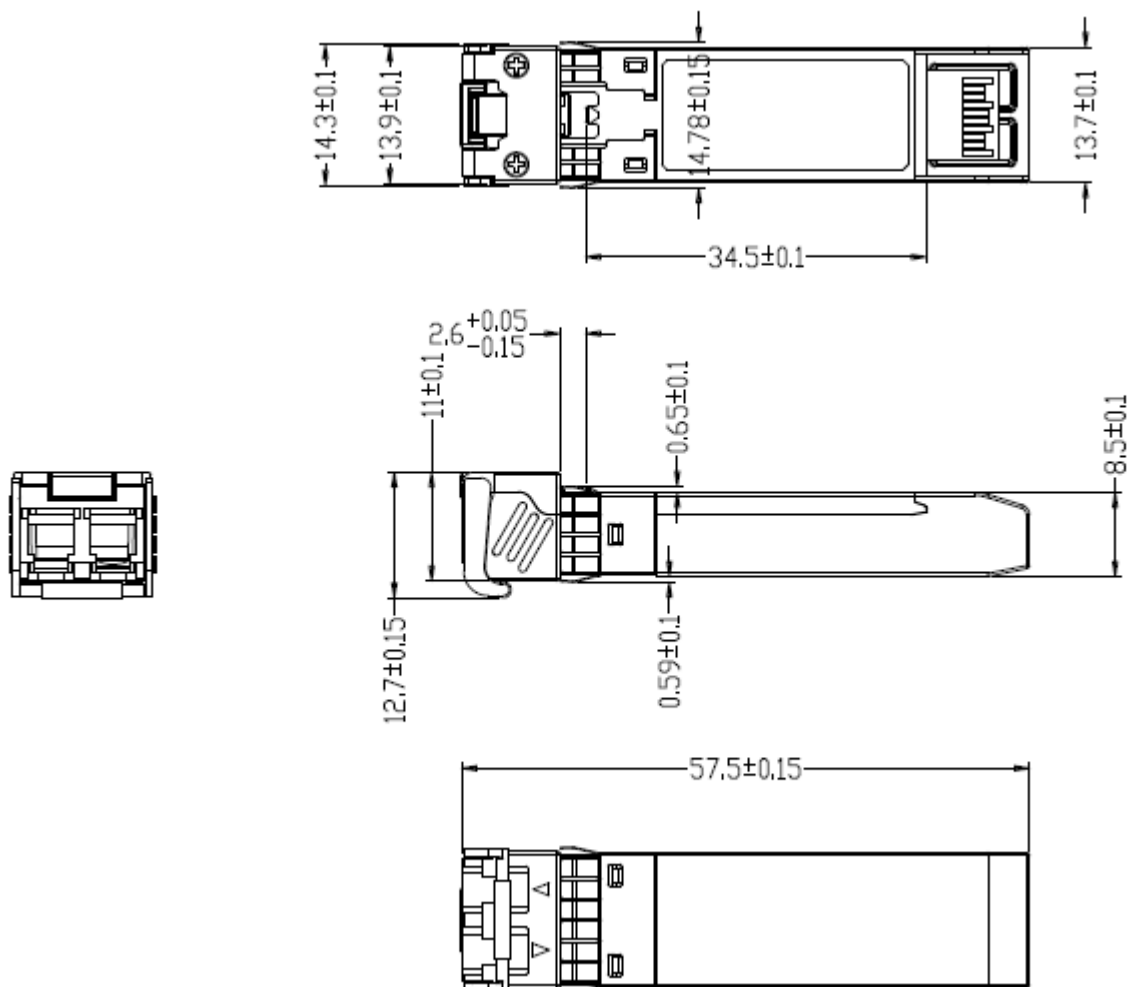

## 13. Module Ordering information

PN	Description
OEFS341	16G SFP+ LW 1310nm 10KM DDMI 0~70 °C

OCRE COMMUNICATION LIMITED Web: ww.ocrecom.com E-Mail: sales@ocrecom.com Add. Dist.A, Building 6, Bay on the six block, Xixiang, Baoan Dist, Shenzhen, China 518000 Tel: + 86 755 2335 3855 Fax: + 86 755 2335 3855	DESIGN	CHECK	CHECK	APPROVAL