



Datasheet

No.

DS10-F003

Initial Date

2010-07-29

OF

OF6S541

Written Team

R&D Dept.

GH Zheng

I Preview

PN	OF6S541
Description	XFP 1550nm ER 40KM

II Contents

1. Features
2. Applications
3. Description
4. Absolute maximum Ratings
5. Operating Environment
6. Optical Characteristics
7. Electrical Characteristics
8. Pin Information
9. Management Interface
10. Recommended Host Board Power Supply Circuit
11. Recommended High-speed Interface Circuit
12. Mechanical Dimensions
13. Model Name Information

III Revision History

No.	Date	Items	Change Recording	Ver.	Rev.	Customer
1	2010-07-29	All	Initial registration	000	000	Standard
2						
3						
4						
5						
6						

 CRE Communication Limited	Datasheet		DS10-F003 Final Rev.:2010.07.29	
	Product	XFP transceiver OF serials	Ver.	000
	Part No.	OF6S541	Rev.	000
			Page	2 / 8

1. Features:

- ◆ Supports 8.0Gb/s to 11.1Gb/s bit rates
- ◆ Hot-pluggable XFP footprint, Built-in digital diagnose
- ◆ Maximum link length of 40KM with SMF
- ◆ 1550nm Cooled EML laser and PIN photodiode
- ◆ XFP MSA package with duplex LC connector
- ◆ No reference clock required
- ◆ Single +3.3V power supply
- ◆ Power dissipation <1.5W
- ◆ Compatible with RoHS
- ◆ Temperature range: 0 to +70°C

2. Applications:

- ◆ SONET OC-192&SDH STM-64 at 9.953Gbps
- ◆ 10GBASE-SR/SW 10G Ethernet
- ◆ 1200-MX-SN-I 10Gigabit Fiber Channel
- ◆ 10GE over G.709 at 11.09Gbps
- ◆ OC192 over FEC at 10.709Gbps
- ◆ Other optical links, up to 11.3Gbps

3. Description:

OF6S541 is compliant with the 10G Small Form-Factor Pluggable (XFP) Multi-Source Agreement (MSA), supporting data-rate of 8.0~11.1Gbps, and transmission distance up to 40Km with SMF. The transceiver module comprises a transmitter with 1550 Cooled EML laser and a receiver with a PIN photodiode. Transmitter and receiver are separate within a wide temperature range and offers optimum heat dissipation and excellent electromagnetic shielding thus enabling high port densities for 10 GbE systems.

4. Absolute Maximum Ratings

Parameter	Symbol	Remarks	Min.	Max.
Storage Temperature	T _{ST}	-40	+85	°C
Supply Voltage	V _{CC3}	0.0	+3.6	V
Relative Humidity	RH	5	95	%

5. Operation Environment:

Parameter	Symbol	Min	Typ	Max	Unit
Date Rate			10.3125		Gb/s

OCRE COMMUNICATION LIMITED Web: www.ocrecom.com E-Mail: sales@ocrecom.com Add. Dist.A, Building 6, Bay on the six block, Xixiang, Baoan Dist, Shenzhen, China 518000 Tel: + 86 755 2335 3855 Fax: + 86 755 2335 3855	DESIGN	CHECK	CHECK	APPROVAL

 CRE Communication Limited	Datasheet		DS10-F003 Final Rev.:2010.07.29	
	Product	XFP transceiver OF serials	Ver.	000
	Part No.	OF6S541	Rev.	000
			Page	3 / 8

Supply Voltage	V _{CC}	+3.14	3.3	+3.47	V
Supply Current	I _{CC}			250	mA
Power Dissipation	PD		600	800	mW
Operating Temperature	T _{OP}	0	25	+70	°C

6. Optical Characteristics (Condition: T_a=T_{OP})

Parameter	Symbol	Min	Typ	Max	Unit	Ref.	
Transmitter							
Date Rate			10.3125		Gb/s		
Optical Wavelength	λ	1530	1550	1565	nm		
Average output power	P _o	-1		2	dBm	1	
Optical Extinction Ratio	ER	8.2			dB	1	
Laser Off Power	P _{off}	-	-	-30	dBm		
RMS spectral width	Δλ			0.45	nm		
Disabled Power	P _{off}	-		-30	dBm		
Dispersion penalty	TDP			3.9	dB		
Tx Jitter	T _{xj}	Per 802.3ae requirements					
Receiver							
Date Rate			10.3125		Gb/s		
Optical Wavelength	λ	1260		1600	nm		
Receiver Sensitivity(OMA)	R			-15.5	dBm	1	
Stressed Receiver Sensitivity(OMA)	R			-7.5	dBm	2	
Maximum Input Power	P _{MAX}	0			dBm		
LOS De-Assert	LOSD			-17	dBm		
LOS Assert	LOSA	-26			dBm		
LOS Hysteresis		0.5		4	dB		
Receiver Reflectance				-12	dB		

Notes:

- 1) Measured at 10.3125Gb/s with PRBS 2³¹ - 1 NRZ test pattern.
- 2) Under the ER worst case, measured at 10.3125 Gb/s with PRBS 2³¹ - 1 NRZ test pattern for BER < 1x10⁻¹²

7. Electrical Characteristics (Condition: T_a=T_{OP})

Parameter	Symbol	Min	Typ	Max	Unit	Note
Transmitter:						
Differential input voltage swing	V _I	90		350	mV _{pp}	1
C common mode voltage tolerance		15	-	-	mV	
Transmit Disable Input	H	V _{IH}	2.0	V _{CC} +0.3	V	
	L	V _{IL}	0	0.8	V	
Transmit Enable Output	H	V _{OH}	2.4	V _{CC} +0.3	V	
	L	V _{OL}	0	0.4	V	2

OCRE COMMUNICATION LIMITED Web: www.ocrecom.com E-Mail: sales@ocrecom.com Add. Dist.A, Building 6, Bay on the six block, Xixiang, Baoan Dist, Shenzhen, China 518000 Tel: + 86 755 2335 3855 Fax: + 86 755 2335 3855	DESIGN	CHECK	CHECK	APPROVAL

 CRE Communication Limited	Datasheet		DS10-F003 Final Rev.:2010.07.29	
	Product	XFP transceiver OF serials	Ver.	000
	Part No.	OF6S541	Rev.	000
			Page	4 / 8

Data Dependent Input Jitter	DDJ			0.1	UI	
Data Input Total Jitter	TJ			0.28	UI	
Input Differential Impedance	Z _{in}	80	100	120	Ω	
Receiver:						
Differential output voltage swing		300		850	mVpp	3
LOS Output	H	V _{OH}	24	V _{cc} +0.3	V	2
	L	V _{OL}	0	0.4	V	
Rx Output Rise and Fall Time	Tr/Tf	30			ps	20% to 80%
Total Jitter	TJ			0.7	UI	
Deterministic Jitter	DJ			0.42	UI	
Output Differential Impedance	Z _{on}	80	100	120	Ω	

Notes:

- 1) TD+/- are internally AC coupled with 100Ω differential termination inside the module.
- 2) Tx Fault and Rx LOS are open collector outputs, which should be pulled up with 4.7k to 10kΩ resistors on the host board. Pull up voltage between 2.0V and V_{cc}+0.3V.
- 3) RD+/- outputs are internally AC coupled, and should be terminated with 100Ω (differential) at the user SERDES.

8. Pin Information

Diagram of Host Board Connector Block Pin Numbers and Name

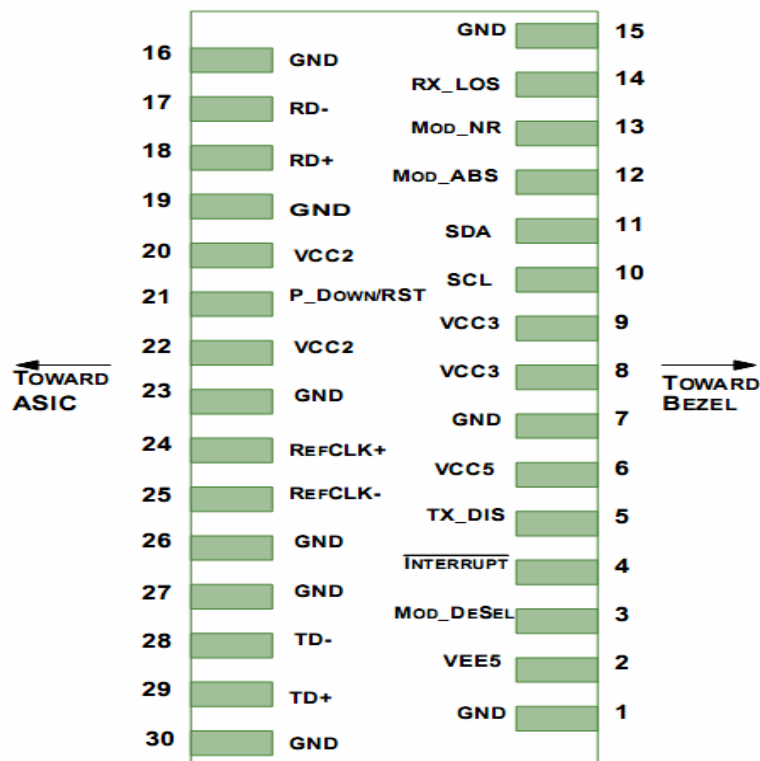

OCRE COMMUNICATION LIMITED Web: www.ocrecom.com E-Mail: sales@ocrecom.com Add. Dist.A, Building 6, Bay on the six block, Xixiang, Baoan Dist, Shenzhen, China 518000 Tel: + 86 755 2335 3855 Fax: + 86 755 2335 3855	DESIGN	CHECK	CHECK	APPROVAL

 Communication Limited	Datasheet		DS10-F003 Final Rev.:2010.07.29	
	Product	XFP transceiver OF serials	Ver.	000
	Part No.	OF6S541	Rev.	000
			Page	5 / 8

Pin	Logic	Symbol	Name/Description	Ref
1		GND	Module Ground	1
2		VEE5	Optional -5.2 Power Supply – Not required	
3	LVTTL-I	Mod-Desel	Module De-select; When held low allows the module to, respond to 2-wire serial interface commands	
4	LVTTL-O	Interrupt	Interrupt (bar); Indicates presence of an important condition which can be read over the serial 2-wire interface	2
5	LVTTL-I	TX_DIS	Transmitter Disable; Transmitter laser source turned off	
6		VCC5	+5 Power Supply – Not required	
7		GND	Module Ground	1
8		VCC3	+3.3V Power Supply	
9		VCC3	+3.3V Power Supply	
10	LVTTL-I	SCL	Serial 2-wire interface clock	2
11	LVTTL-IO	SDA	Serial 2-wire interface data line	2
12	LVTTL-O	Mod_Abs	Module Absent; Indicates module is not present. Grounded in the module.	2
13	LVTTL-O	Mod_NR	Module Not Ready;	2
14	LVTTL-O	RX_LOS	Receiver Loss of Signal indicator	2
15		GND	Module Ground	1
16		GND	Module Ground	1
17	CML-O	RD-	Receiver inverted data output	
18	CML-O	RD+	Receiver non-inverted data output	
19		GND	Module Ground	1
20		VCC2	+1.8V Power Supply – Not required	
21	LVTTL-I	P_Down/ RST	Power Down; When high, places the module in the low power stand-by mode and on the falling edge of P_Down initiates a module reset	
			Reset; The falling edge initiates a complete reset of the module including the 2-wire serial interface. equivalent to a power cycle.	
22		VCC2	+1.8V Power Supply – Not required	
23		GND	Module Ground	1
24	PECL-I	RefCLK+	Reference Clock non-inverted input, AC coupled on the host board – Not required	3
25	PECL-I	RefCLK-	Reference Clock inverted input, AC coupled on the host board – Not required	3
26		GND	Module Ground	1
27		GND	Module Ground	1
28	CML-I	TD-	Transmitter inverted data input	
29	CML-I	TD+	Transmitter non-inverted data input	
30		GND	Module Ground	1

OCRE COMMUNICATION LIMITED Web: www.ocrecom.com E-Mail: sales@ocrecom.com Add. Dist.A, Building 6, Bay on the six block, Xixiang, Baoan Dist, Shenzhen, China 518000 Tel: + 86 755 2335 3855 Fax: + 86 755 2335 3855	DESIGN	CHECK	CHECK	APPROVAL

 CRE Communication Limited	Datasheet		DS10-F003 Final Rev.:2010.07.29	
	Product	XFP transceiver OF serials	Ver.	000
	Part No.	OF6S541	Rev.	000
			Page	6 / 8

Notes:

1. Module circuit ground is isolated from module chassis ground within the module.
2. Open collector, should be pulled up with 4.7k – 10k ohms on host board to a voltage between 3.15V and 3.6V.
3. A Reference Clock input is not required.

9. Management Interface

The transceivers provide serial ID memory contents and diagnostic information about the present operating conditions by the 2-wire serial interface (SCL, SDA).

The Module provides diagnostic information about the present operating conditions. The transceiver generates this diagnostic data by digitization of internal analog signals. Alarm/warning threshold data is written during device manufacture. Received power monitoring, transmitted power monitoring, bias current monitoring, supply voltage monitoring and temperature monitoring all are implemented.

The digital diagnostic memory map specific data field defines as following.

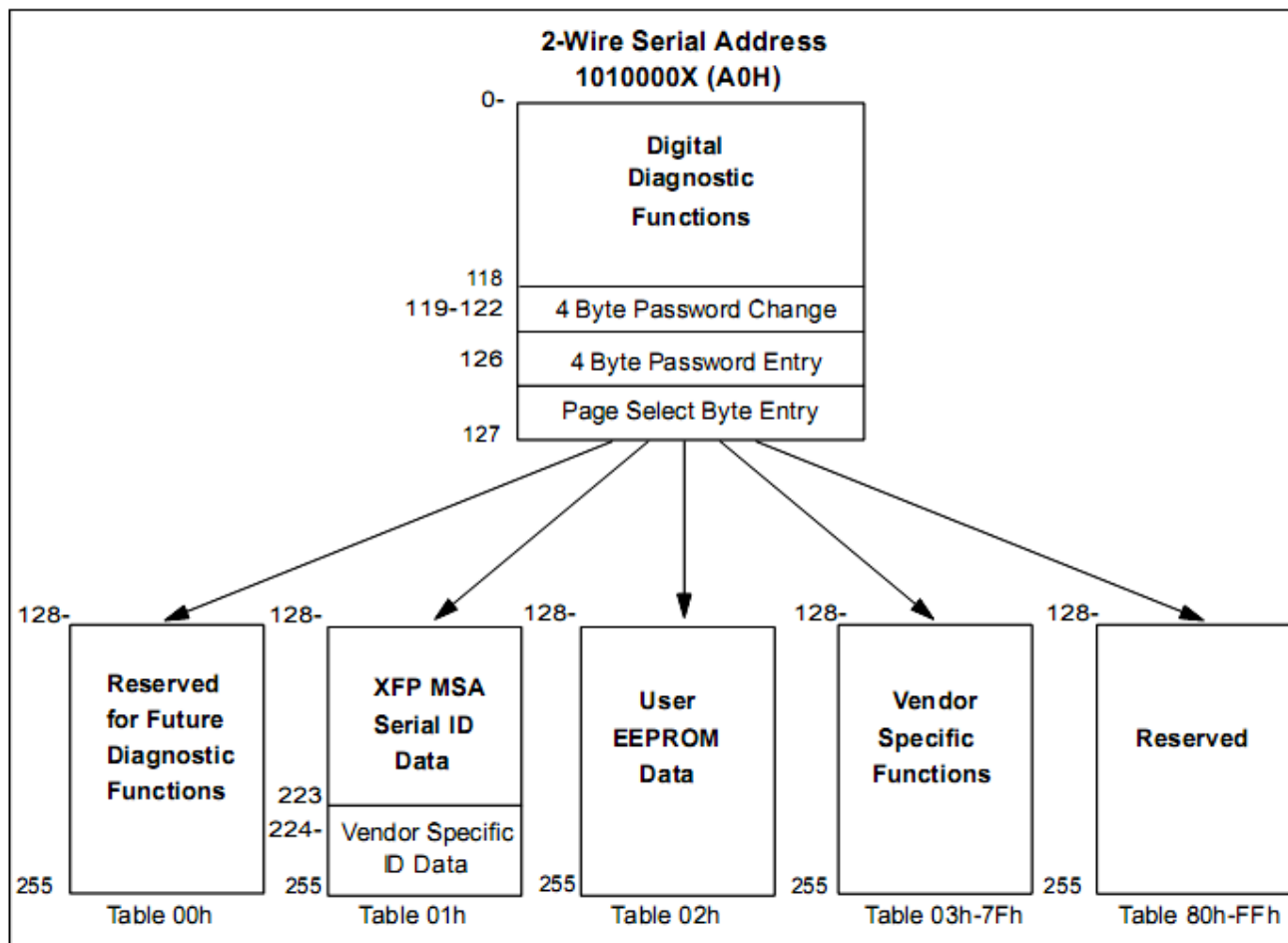

OCRE COMMUNICATION LIMITED Web: www.ocrecom.com E-Mail: sales@ocrecom.com Add. Dist.A, Building 6, Bay on the six block, Xixiang, Baoan Dist, Shenzhen, China 518000 Tel: + 86 755 2335 3855 Fax: + 86 755 2335 3855	DESIGN	CHECK	CHECK	APPROVAL



Communication Limited

Datasheet

DS10-F003
Final Rev.:2010.07.29

Product

XFP transceiver
OF serials

Ver.

000

Part No.

OF6S541

Rev.

000

Page

7 / 8

10. Recommended Host Board Power Supply Circuit

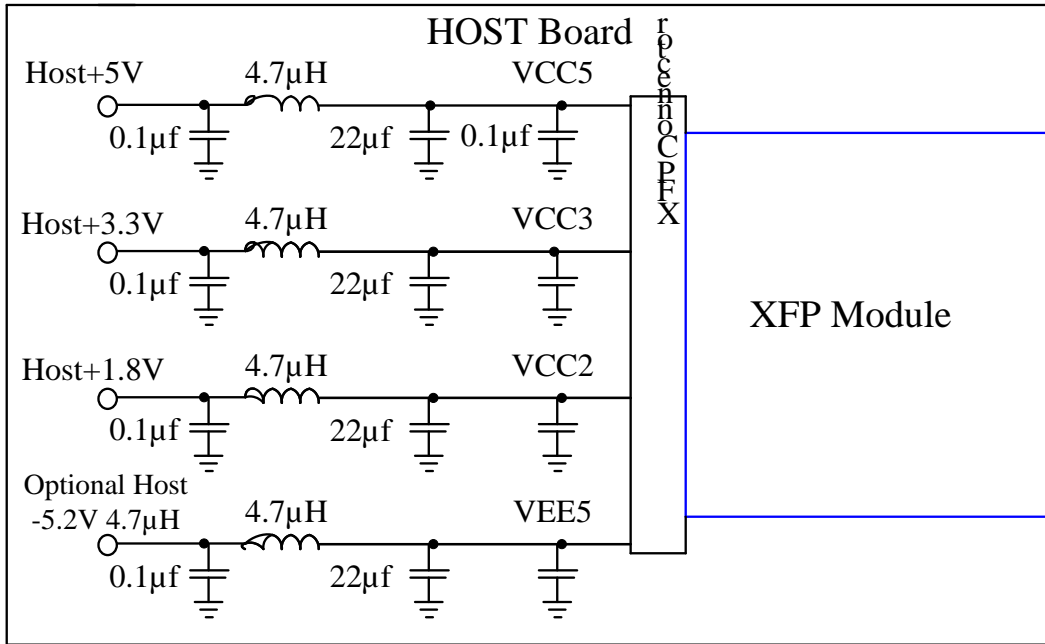

11. Recommended High-speed Interface Circuit

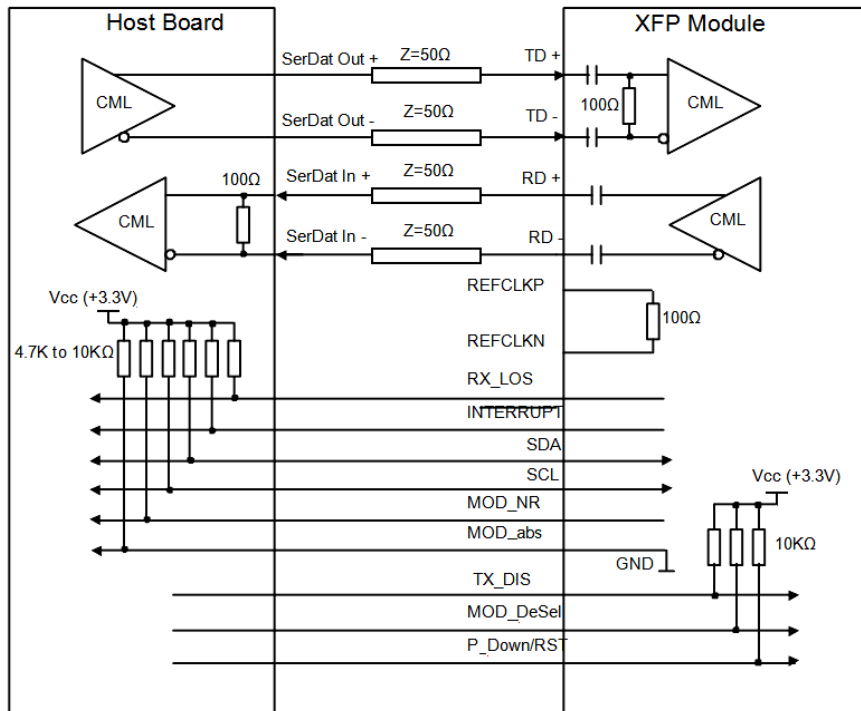

OCRE COMMUNICATION LIMITED

Web: www.ocrecom.com

E-Mail: sales@ocrecom.com

Add. Dist.A, Building 6, Bay on the six block, Xixiang,
Baoan Dist, Shenzhen, China 518000

Tel: + 86 755 2335 3855 Fax: + 86 755 2335 3855

DESIGN

CHECK

CHECK

APPROVAL

 CRE Communication Limited	Datasheet		DS10-F003 Final Rev.:2010.07.29	
	Product	XFP transceiver OF serials	Ver.	000
	Part No.	OF6S541	Rev.	000
			Page	8 / 8

12. Mechanical Dimensions

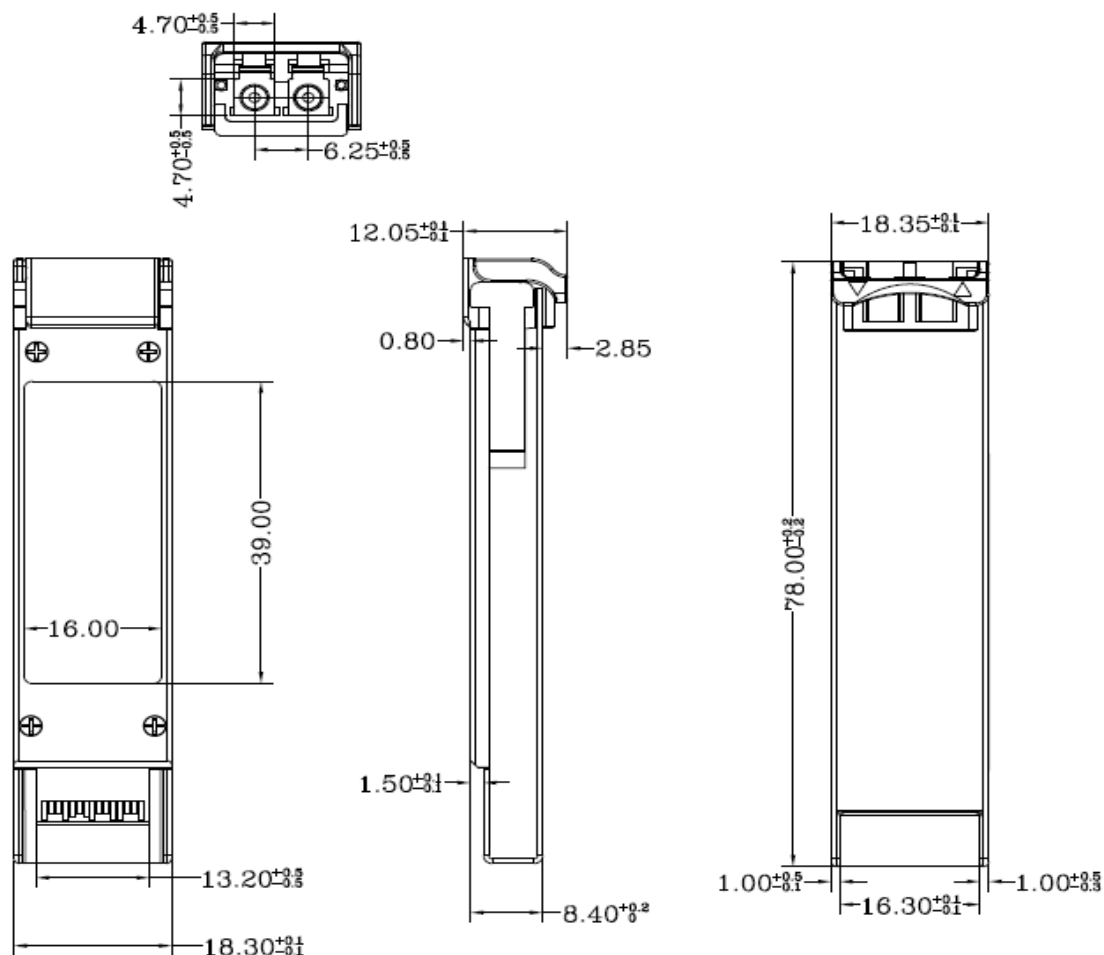

13. Model Name Information

PN	Description
OF6S541	XFP ER 40Km 0~70°C

OCRE COMMUNICATION LIMITED Web: www.ocrecom.com E-Mail: sales@ocrecom.com Add. Dist.A, Building 6, Bay on the six block, Xixiang, Baoan Dist, Shenzhen, China 518000 Tel: + 86 755 2335 3855 Fax: + 86 755 2335 3855	DESIGN	CHECK	CHECK	APPROVAL